

One main reason for brick's popularity with architects, designers and builders is its ability to adapt to design criteria. It can be shaped and used in a wide variety of traditional and contemporary detailing – from arches to sills, copings, columns and treads. Glen-Gery manufactures a complete selection of brick shapes to match its comprehensive line of extruded, molded, and handmade brick.

This catalog illustrates the standardized shapes that are available from Glen-Gery's manufacturing facilities. Their availability may differ from plant to plant depending on the size and type of brick produced. Unit identification, size availability and dimensioning are noted on each shape type, making the ordering process simple and straightforward. For these standard shapes, no drawings are necessary; simply call your Glen-Gery representative with the ordering information.

While these shapes can accomplish a wide variety of architectural detailing, Glen-Gery realizes that the creative process may require shapes that do not fall within standardized design. To meet this need, Glen-Gery Brick is equipped to produce customized shapes that conform to the designer's specifications. Custom shapes can be produced in either extruded, molded or handmade brick types, although some textures may not be available. Because of the technical expertise necessary to produce these custom shapes, it is important to consult with a Glen-Gery Brickwork Design Center or technical advisor for the most practical and cost-effective method of achieving the desired shape.

Glen-Gery's network of Design Advisors are available to coordinate the design and production of custom brick shapes. Please contact them early in the design stage so that all practical options can be explored.

INTRODUCTION	1
TECHNICAL INFORMATION	2-3
Brickwork Design Services	3
WATER TABLES	4-9
On-the-flat	5-7
Rowlock	8-9
SILLS, COPINGS, AND TREADS	10-13
Sills	11-12
Copings	12-13
Treads	13
CORNERS, LIPPED, AND RADIALS	14-19
Corners	14-15
Lipped	15
Radials	16-19
ARCHES	20-21
8-SQUARE SHAPES	22
COATED BRICK SHAPES	23
CUSTOM SHAPES	24

Technical and Specification Information

Glen-Gery standardized shapes can be easily ordered by following the established format. An accurate specification should include the number of pieces, proper shape identification, brick size, brick type and color range, as described in this section. Your Glen-Gery representative will be glad to answer any questions or provide more detailed information on standardized shapes, custom shapes, or other aspects of brickwork design and detailing.

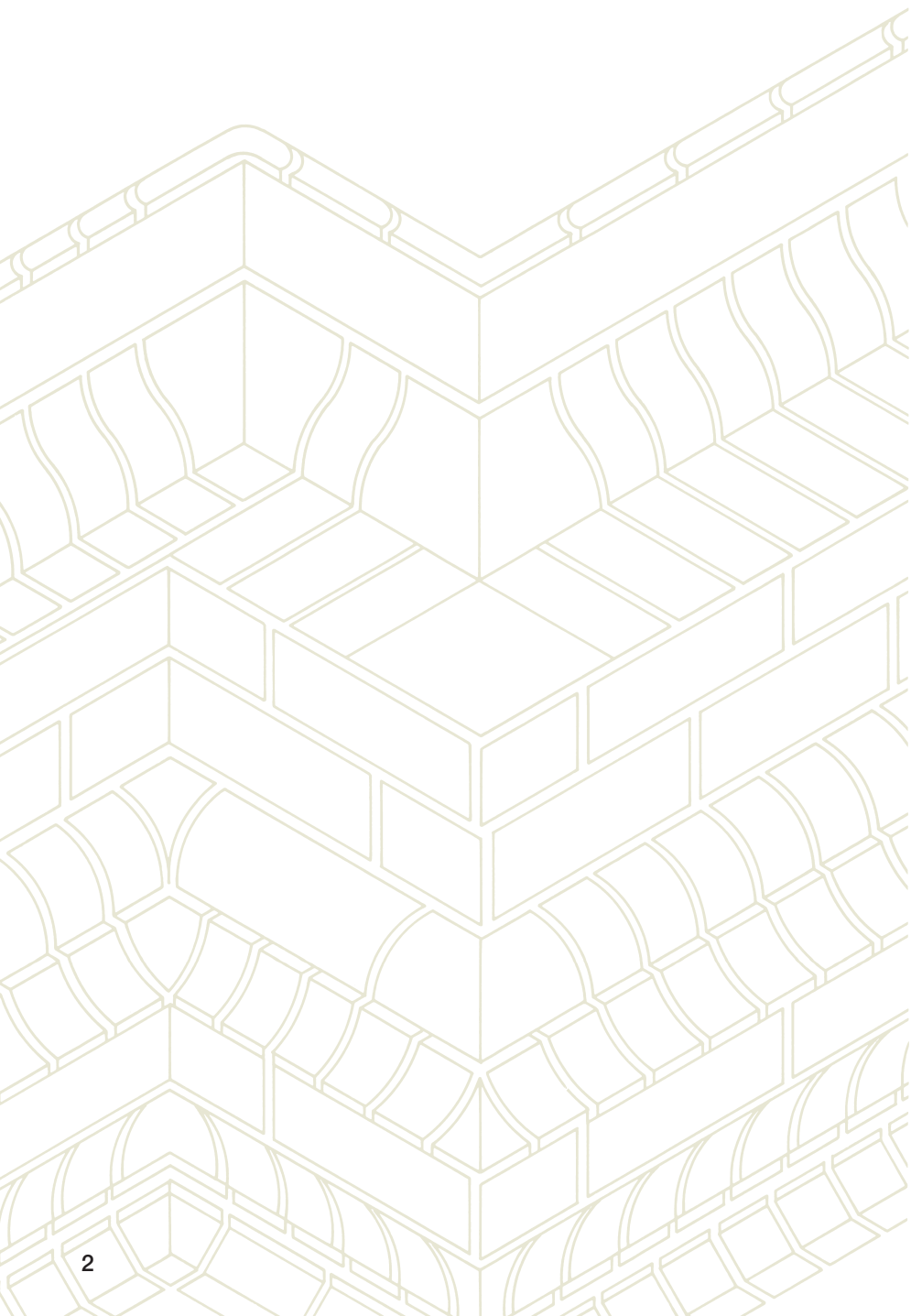

Position of Brick in the Wall

Interesting brickwork design effects can be achieved by placing brick in other than the normal stretcher position, as illustrated below. Regardless of how the brick is installed in the wall, size dimensions (thickness, height and length of the unit) are always assigned from the stretched position.

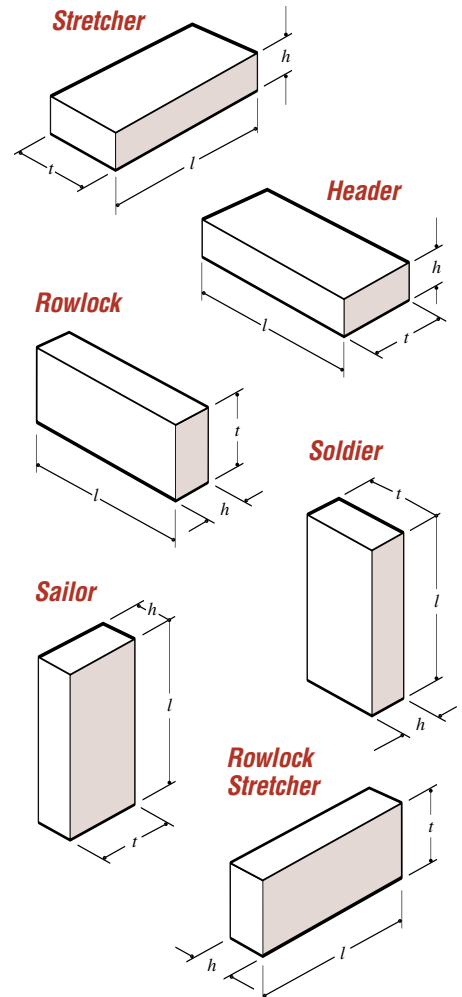

Glen-Gery Brick Sizes for Standard Shapes

	<i>t</i>	<i>h</i>	<i>l</i>
STANDARD	3-5/8"	2-1/4"	8"
STANDARD MOD	3-5/8"	2-1/4"	7-5/8"
ENGINEER STD	3-5/8"	2-3/4"	8"
ENGINEER MOD	3-5/8"	2-3/4"	7-5/8"
ECONOMO	3-5/8"	3-5/8"	7-5/8"
UTILITY	3-5/8"	3-5/8"	11-5/8"
*HMOS	4"	2-3/4"	8-1/2"

*Handmade Oversize

Glen-Gery Brick Types

**Extruded
ETD**



**Molded
M**



**Handmade
HM**



**Glazed
GL**



Brick Colors & Textures

Glen-Gery provides a wide selection of brick colors including ranges of white, buff, grey, red, and brown in both through-the-body and sand finished brick. Glazed and claycoat brick are available in standard colors as well as an unlimited range of custom colors. Custom colors often require a minimum order. More than thirty different textures are available ranging from architectural smooth and glazed to a rough bark finish. Availability of color and texture varies from plant to plant depending on the type of brick produced.

Coring

Coring of standardized brick shapes is a plant option. Any coring requirements to these shapes places them into a custom shape category – requiring drawings.

Shape Identification

W – Water Table	LT – Left	HB – Hingebriek
H – Header	RT – Right	8SQ – Eight Square
S – Stretcher	SL – Sill	K – Kerfed
EX – External	CO – Coping	FA – Flat Arch
IN – Internal	T – Tread	(or) – Requires Choice
R – Rowlock	RA – Radial	x/y – Unit serves both functions
ST – Starter	LP – Lipped	1-1/1 – Specific unit size
	O – Octagon	

☐ Throughout this catalog shaded areas denote finished faces.

For Example



Shape Specification

The following information is required when ordering shapes from this catalog.

Please check with your Glen-Gery representative to ensure that the standardized shape & size requested is available in the specified type and color.

<u>500</u>	<u>W1-R-ST-RT</u>	<u>ECONOMO</u>	<u>ETD</u>	<u>FALL GREY</u>
# pieces	Shape ID	Brick Size	Brick Type	Brick Color

Glen-Gery Design Advisors share their expertise.

Since its founding a century ago, Glen-Gery has been committed to providing high quality products and professional services to the design/builder community.

Our team of Design Advisors fulfill this promise by offering practical advice, valuable insights and useful recommendations. As professional engineers, they have a complete understanding of the technical applications, requirements and considerations for proper brickwork design. Some of their many areas of expertise include preventing water penetration, custom shape design, differential movement and exterior paving with brick.

As a service to clients, Glen-Gery Design Advisors are also available to consult on plan reviews and perform on-site field investigations.

These complimentary services are provided to the professional design and construction community to underscore Glen-Gery's dedication to the promotion of excellence in brickwork design.

On-the-flat Water Table Systems

There are two types of on-the-flat water table systems based on the brick position in the wall.

- 1) Water table in the header position (**H**).
- 2) Water table in the stretcher position (**S**).

Each system is available with companion exterior and interior corners.

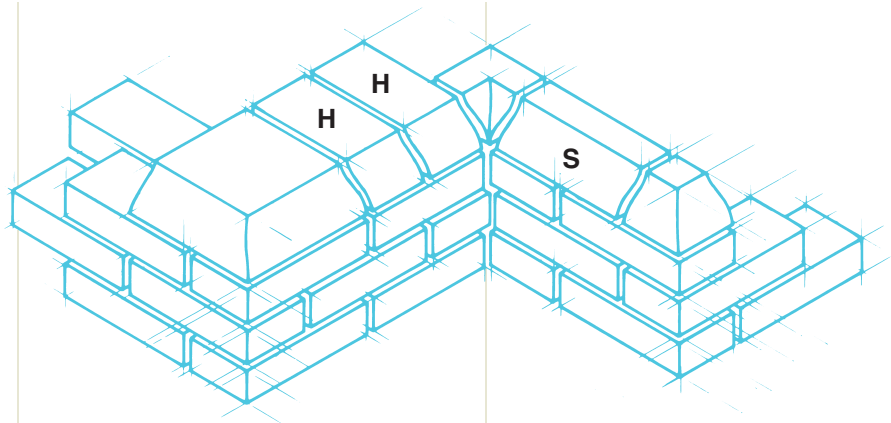

Rowlock Water Table Systems

- 1) Water table in the rowlock brick position (**R**).

In this application, rowlock water tables have been rotated to the header position (**H**).

Water tables can also be turned upside down to achieve a cornice detail.

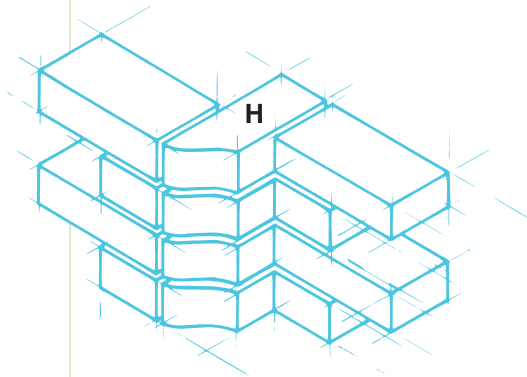
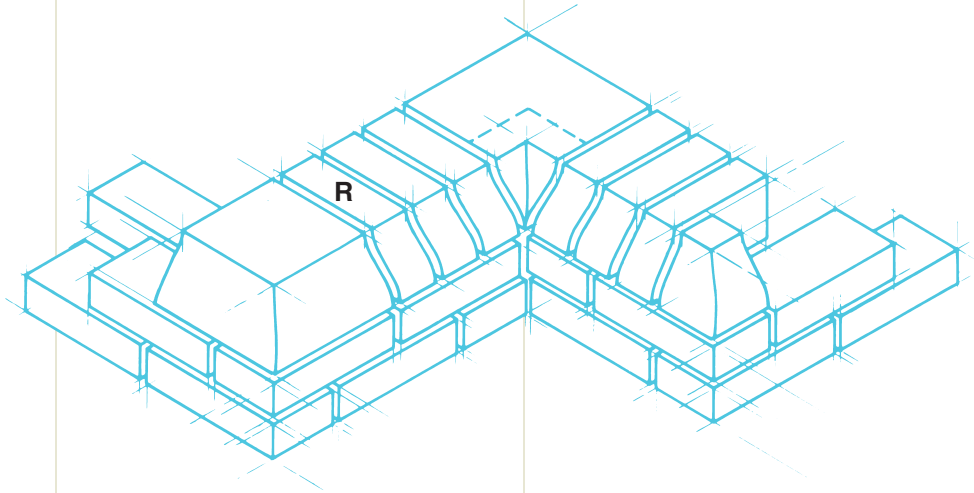

Water Tables

Rowlock and on-the-flat water tables, once used to reduce water penetration, are now used by architects and designers to achieve decorative design details. These details can range from the use of a single style for simplicity to a combination of styles to achieve highly ornate brickwork. In addition to their traditional use, these shapes can be used to add dimension to flat walls, rotated to form door and window jambs, or inverted to form cornice brickwork. Continuity of design can also be transferred into the landscape by using the water tables as caps for walls or edging accents for walkways.

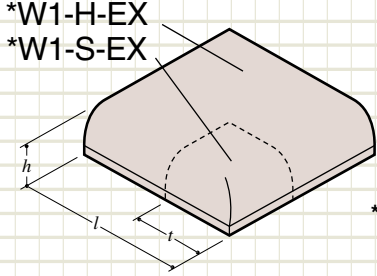
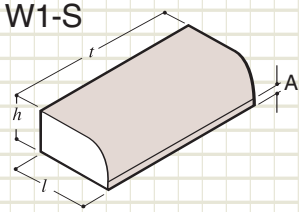
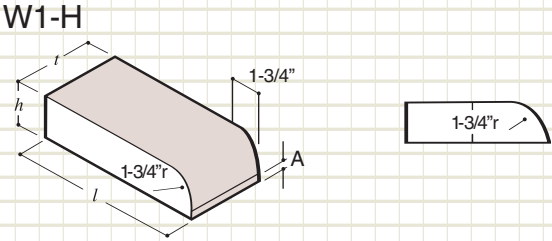

***NOTE:**
The header and stretcher shapes of the W1-EX and W1-IN can be used with either the W1-H or W1-S.

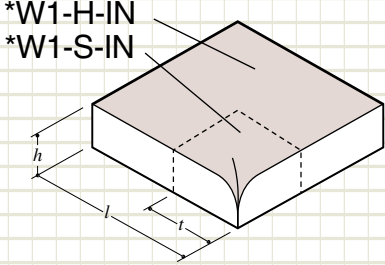

ON-THE-FLAT	t	h	l	A
STANDARD	3-5/8"	2-1/4"	8"	1/2"
STANDARD MOD	3-5/8"	2-1/4"	7-5/8"	1/2"
ENGINEER STD	3-5/8"	2-3/4"	8"	1"
ENGINEER MOD	3-5/8"	2-3/4"	7-5/8"	1"
ECONOMO	3-5/8"	3-5/8"	7-5/8"	1-7/8"
UTILITY	3-5/8"	3-5/8"	11-5/8"	1-7/8"
HMOS	4"	2-3/4"	8-1/2"	1"

Water Tables on-the-flat

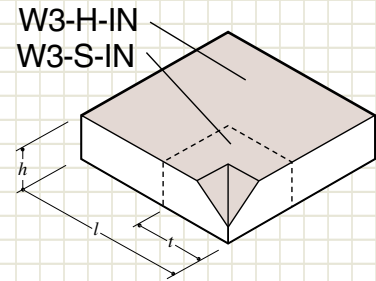
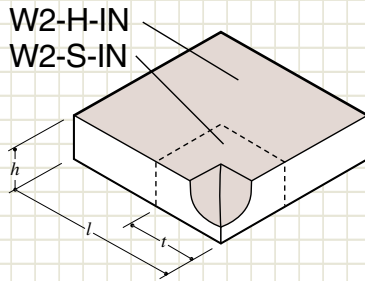
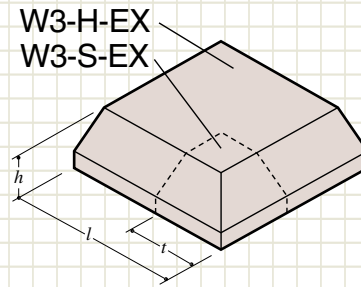
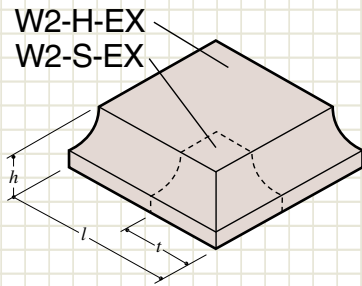
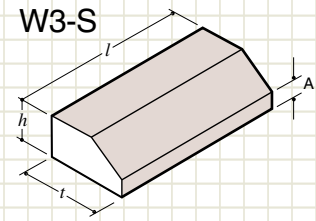
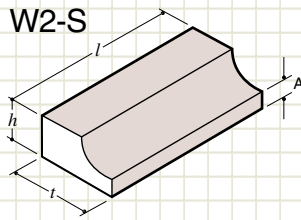
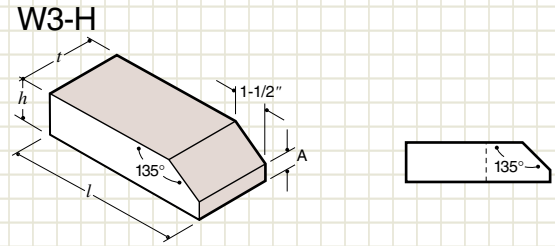
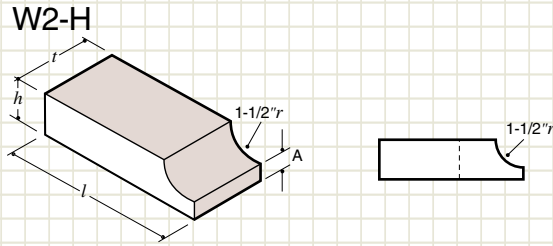

ON-THE-FLAT	t	h	l	A
STANDARD	3-5/8"	2-1/4"	8"	3/4"
STANDARD MOD	3-5/8"	2-1/4"	7-5/8"	3/4"
ENGINEER STD	3-5/8"	2-3/4"	8"	1-1/4"
ENGINEER MOD	3-5/8"	2-3/4"	7-5/8"	1-1/4"
ECONOMO	3-5/8"	3-5/8"	7-5/8"	2-1/8"
UTILITY	3-5/8"	3-5/8"	11-5/8"	2-1/8"
HMOS	4"	2-3/4"	8-1/2"	1-1/4"

ON-THE-FLAT	t	h	l	A
STANDARD	3-5/8"	2-1/4"	8"	3/4"
STANDARD MOD	3-5/8"	2-1/4"	7-5/8"	3/4"
ENGINEER STD	3-5/8"	2-3/4"	8"	1-1/4"
ENGINEER MOD	3-5/8"	2-3/4"	7-5/8"	1-1/4"
ECONOMO	3-5/8"	3-5/8"	7-5/8"	2-1/8"
UTILITY	3-5/8"	3-5/8"	11-5/8"	2-1/8"
HMOS	4"	2-3/4"	8-1/2"	1-1/4"

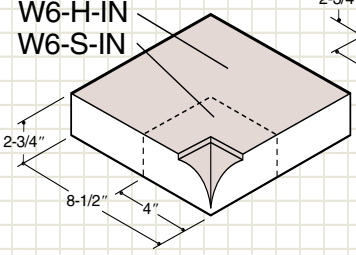
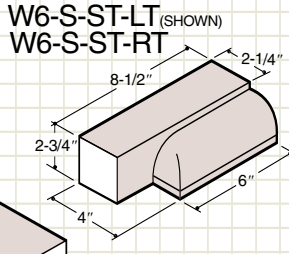
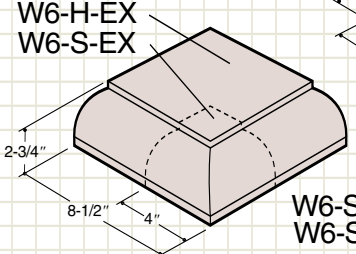
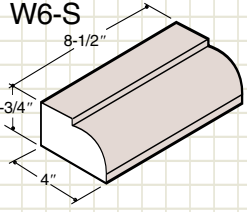
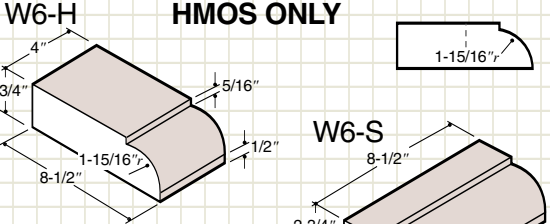
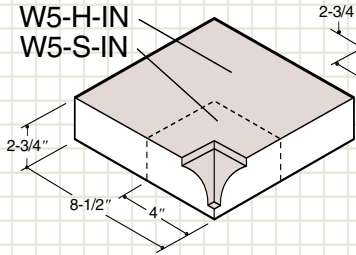
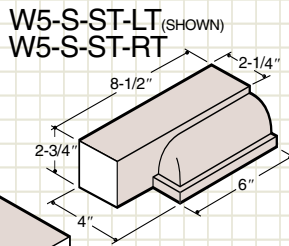
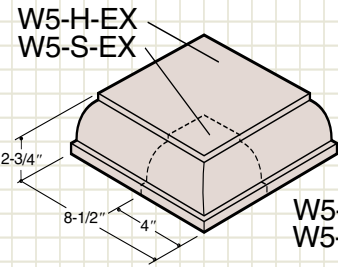
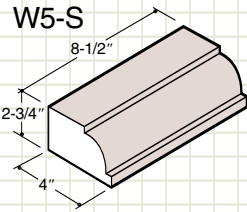
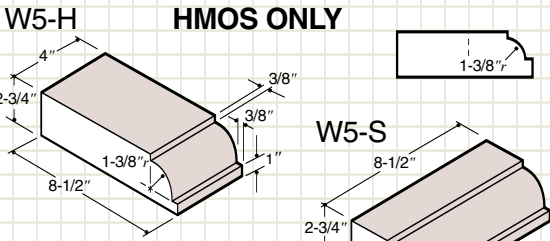
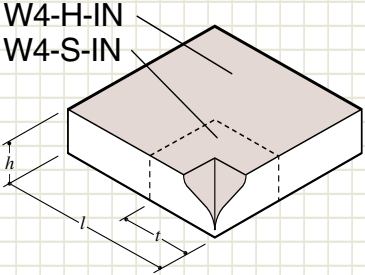
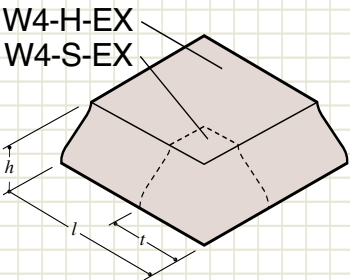
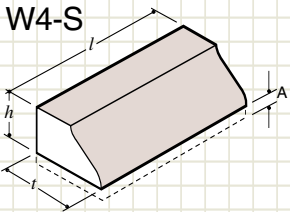
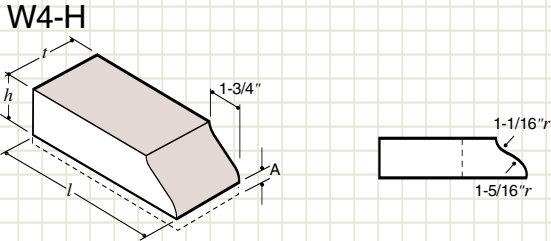

ON-THE-FLAT	t	h	l	A
STANDARD	3-5/8"	2-1/4"	8"	—
STANDARD MOD	3-5/8"	2-1/4"	7-5/8"	—
ENGINEER STD	3-5/8"	2-3/4"	8"	3/8"
ENGINEER MOD	3-5/8"	2-3/4"	7-5/8"	3/8"
ECONOMO	3-5/8"	3-5/8"	7-5/8"	1-1/4"
UTILITY	3-5/8"	3-5/8"	11-5/8"	1-1/4"
HMOS	4"	2-3/4"	8-1/2"	3/8"

Water Tables rowlock

W7-R

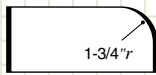
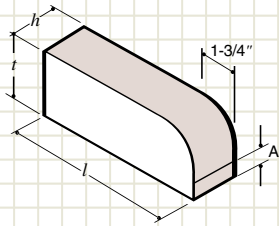

W7-R-EX-l
W7-R-EX-t

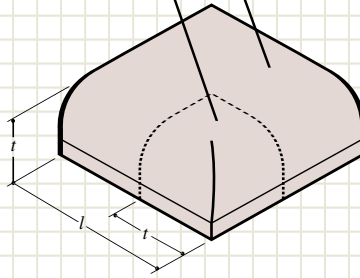

W7-R-IN-l
W7-R-IN-t

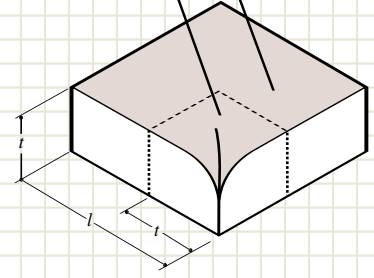

W8-R

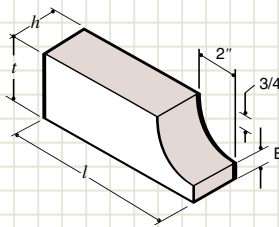

W8-R-EX-l
W8-R-EX-t

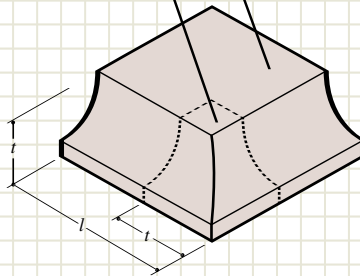

W8-R-IN-l
W8-R-IN-t

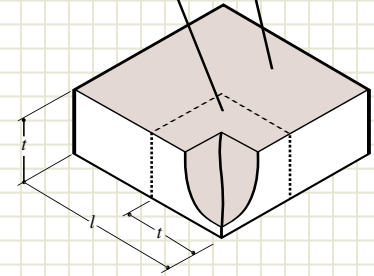

W9-R

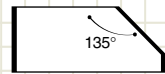
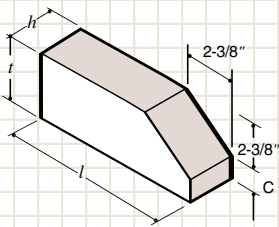

W9-R-EX-l
W9-R-EX-t

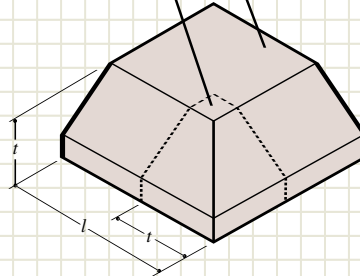

W9-R-IN-l
W9-R-IN-t

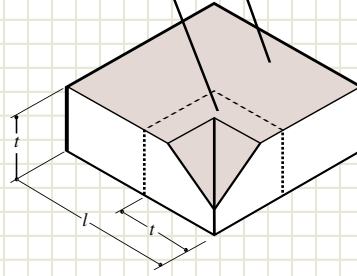

W10-R

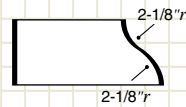
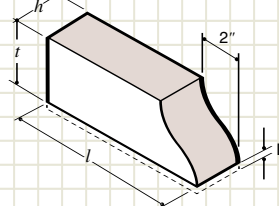

W10-R-EX-l
W10-R-EX-t

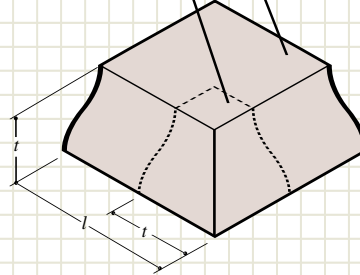

W10-R-IN-l
W10-R-IN-t

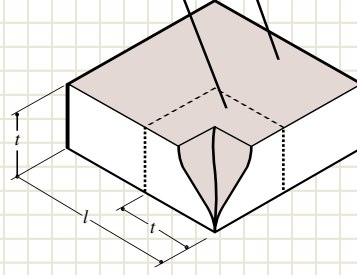

ROWLOCK	t	h	l	A	B	C	D	E	F
STANDARD	3-5/8"	2-1/4"	8"	1-7/8"	7/8"	1-1/4"	—	3/8"	3/4"
STANDARD MOD	3-5/8"	2-1/4"	7-5/8"	1-7/8"	7/8"	1-1/4"	—	3/8"	3/4"
ENGINEER STD	3-5/8"	2-3/4"	8"	1-7/8"	7/8"	1-1/4"	—	3/8"	3/4"
ENGINEER MOD	3-5/8"	2-3/4"	7-5/8"	1-7/8"	7/8"	1-1/4"	—	3/8"	3/4"
ECONOMO	3-5/8"	3-5/8"	7-5/8"	1-7/8"	7/8"	1-1/4"	—	3/8"	3/4"
UTILITY	3-5/8"	3-5/8"	11-5/8"	1-7/8"	7/8"	1-1/4"	—	3/8"	3/4"
HMOS	4"	2-3/4"	8-1/2"	2-1/4"	1-1/4"	1-5/8"	3/8"	3/4"	1-1/8"

Table at left refers to isometric drawings W7-R through W12-R.

W11-R

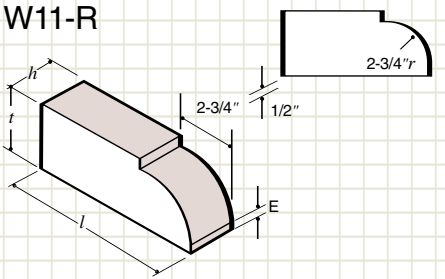

W11-R-EX-l
W11-R-EX-t

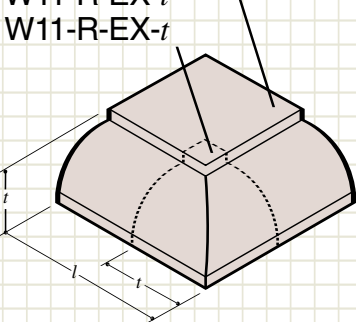

W11-R-IN-l
W11-R-IN-t

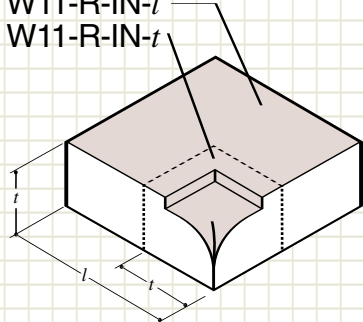

W12-R

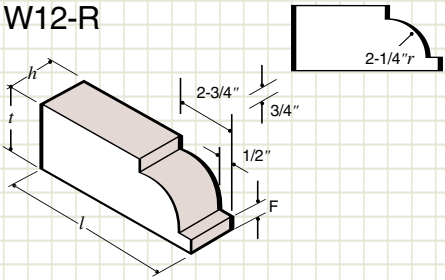

W12-R-EX-l
W12-R-EX-t

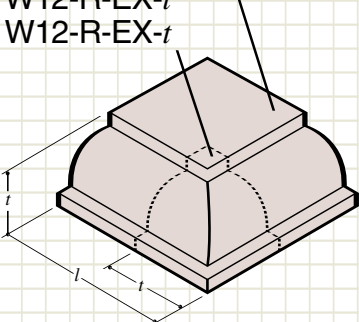

W12-R-IN-l
W12-R-IN-t

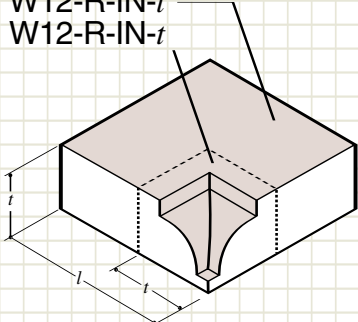

W13-R

HMOS ONLY

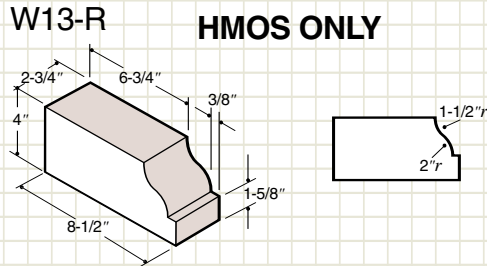

W13-R-EX-8 1/2"
W13-R-EX-4"

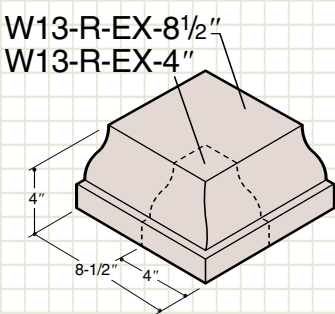

W13-R-IN-8 1/2"
W13-R-IN-4"

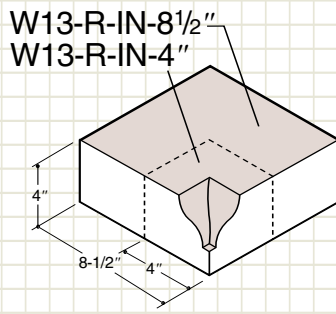

W13-R-ST-LT (SHOWN)
W13-R-ST-RT

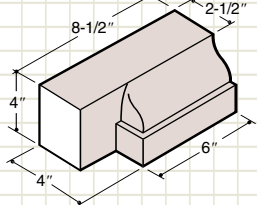

W14-R-ST-LT (SHOWN)
W14-R-ST-RT

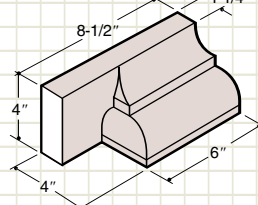

W14-R

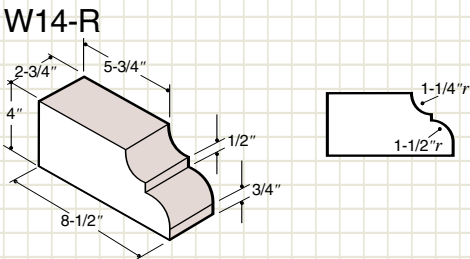

W14-R-EX-8 1/2"
W14-R-EX-4"

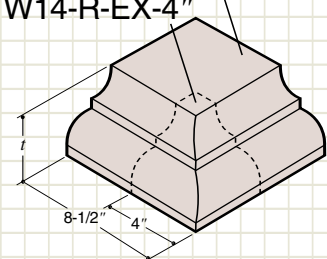

W14-R-IN-8 1/2"
W14-R-IN-4"

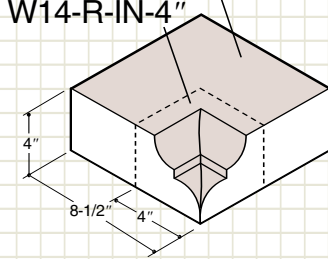

Sill Systems

Sills are used to protect the brick masonry below a window or door opening from water penetration. Their design forces water away from these critical areas. These shapes are available with companion left and right starters. When ordering these starters, please specify left or right.

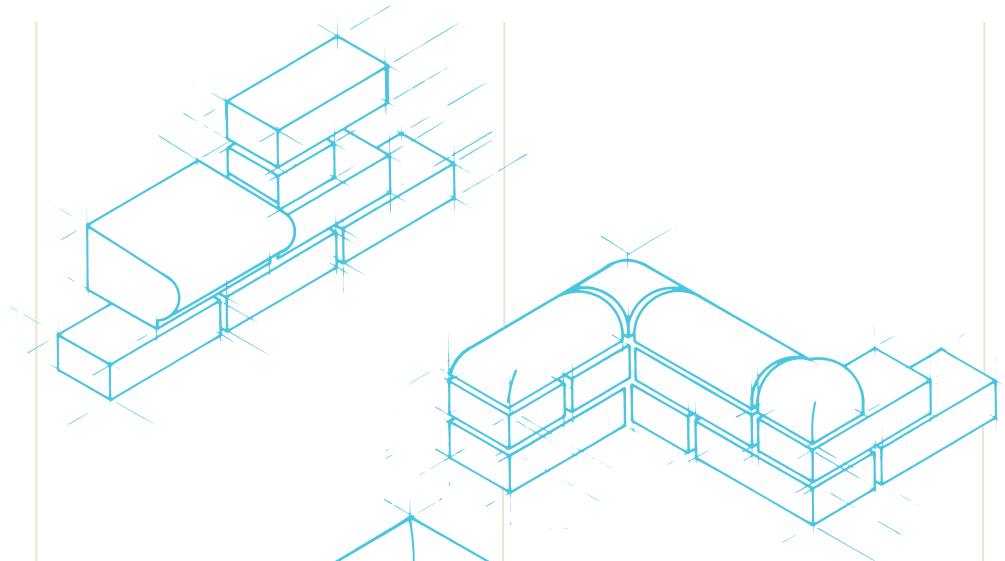

Coping Systems

Copings form a cap on top of a wall that protects the brick masonry below from water penetration. Their design forces water to run off while exposing a minimum number of mortar joints. These shapes and their companion exterior/ interior corners and starters are available in sizes that cap walls constructed of 1-3 wythes of brick.

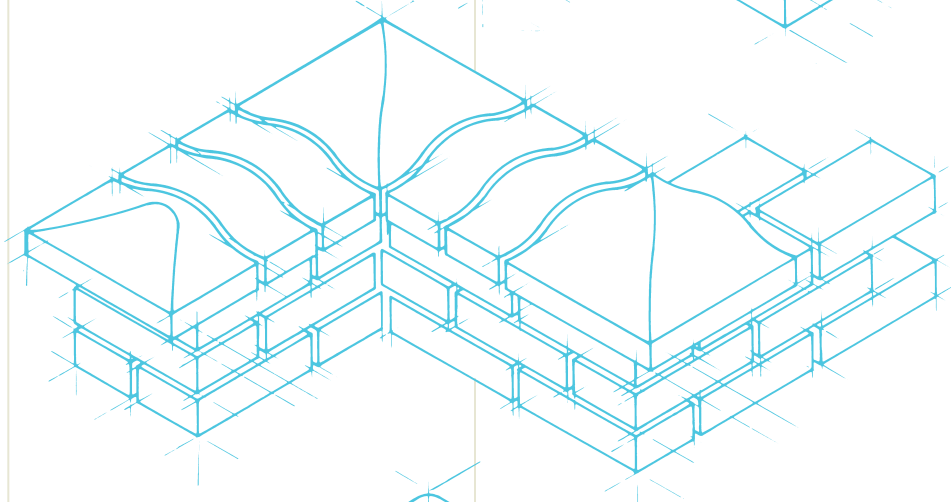

Tread Systems

Treads are designed with curves that add safety and beauty to a stairway. They are available in 3-5/8" and 7-5/8" units (4" and 8-1/2" for HMOS) along with their companion corner units.

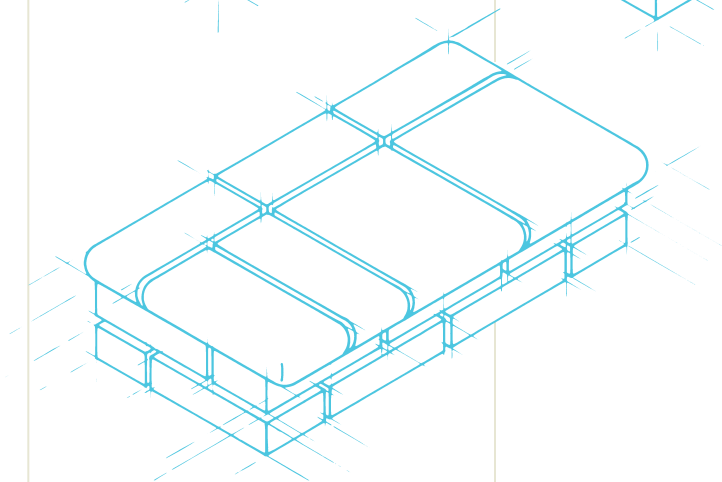

Sills, Copings, and Treads



The basic function of copings and sills is to reduce the potential for water penetration. This is easily and attractively accomplished with a variety of Glen-Gery brick shapes. Their profiles, whether

angular or curvilinear, add distinctive detailing to wall caps, windows, and door openings. Tread shapes are manufactured to properly finish brick steps and other paving applications.

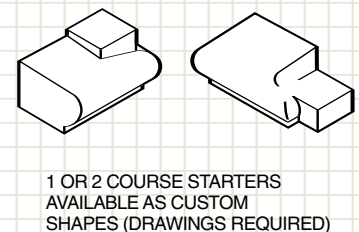
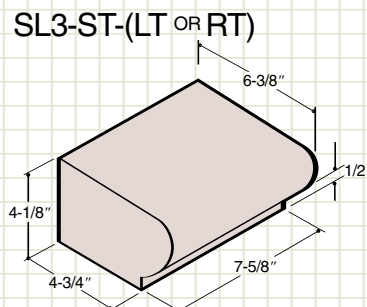
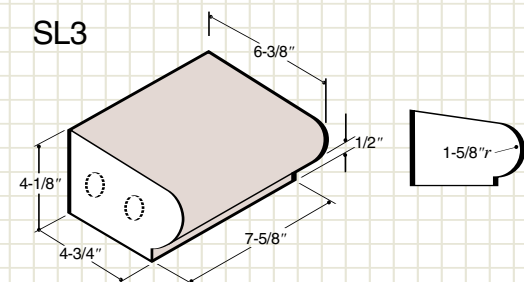
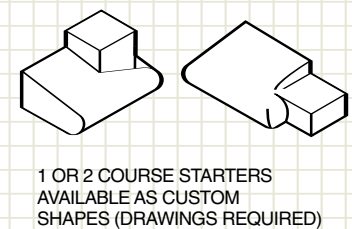
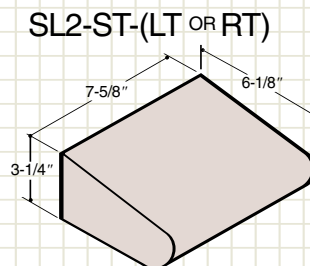
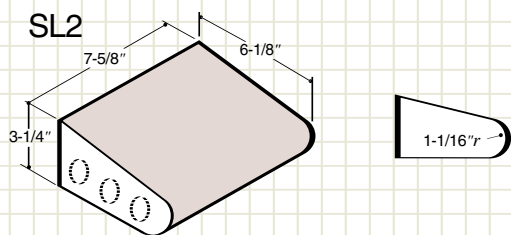
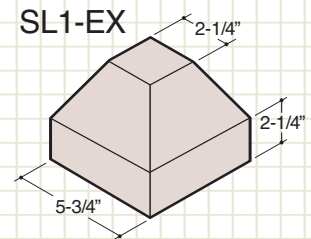
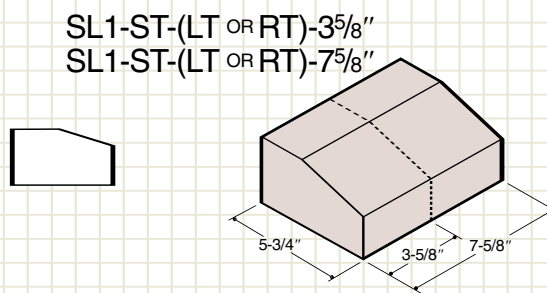
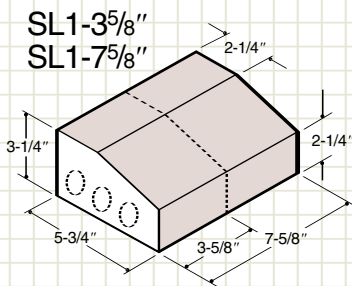

Sills and Copings

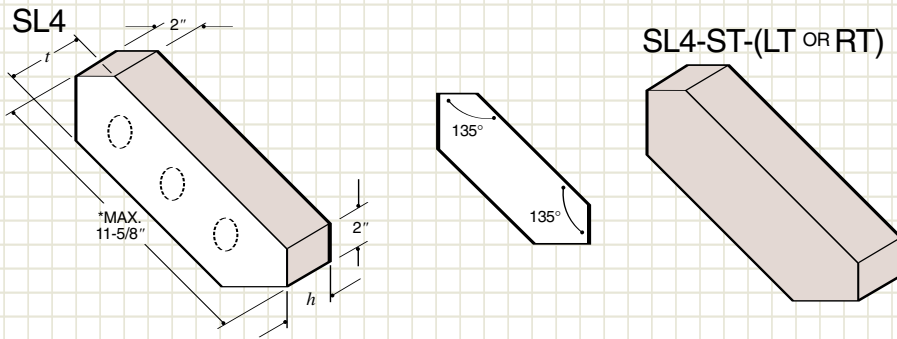

*Length is variable and must be specified.

SL4	<i>t</i>	<i>h</i>
STANDARD	3-5/8"	2-1/4"
STANDARD MOD	3-5/8"	2-1/4"
ENGINEER STD	3-5/8"	2-3/4"
ENGINEER MOD	3-5/8"	2-3/4"
ECONOMO	3-5/8"	3-5/8"
UTILITY	3-5/8"	3-5/8"
HMOS	4"	2-3/4"

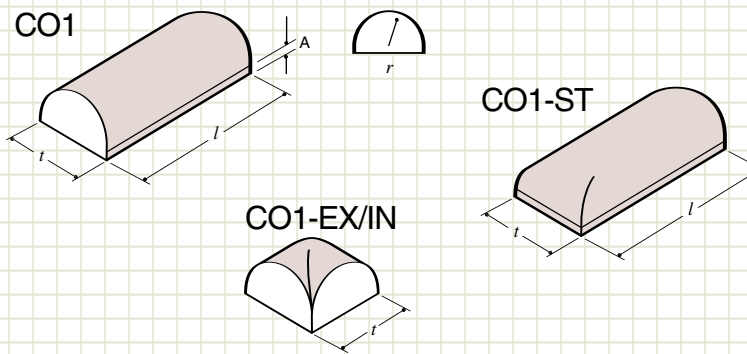

CO1	<i>t</i>	<i>l</i>	<i>r</i>	<i>A</i>
STANDARD	3-5/8"	8"	1-13/16"	3/8"
STANDARD MOD	3-5/8"	7-5/8"	1-13/16"	3/8"
ENGINEER STD	3-5/8"	8"	1-13/16"	3/8"
ENGINEER MOD	3-5/8"	7-5/8"	1-13/16"	3/8"
ECONOMO	3-5/8"	7-5/8"	1-13/16"	3/8"
UTILITY	3-5/8"	11-5/8"	1-13/16"	3/8"
HMOS	4"	8-1/2"	2"	3/4"

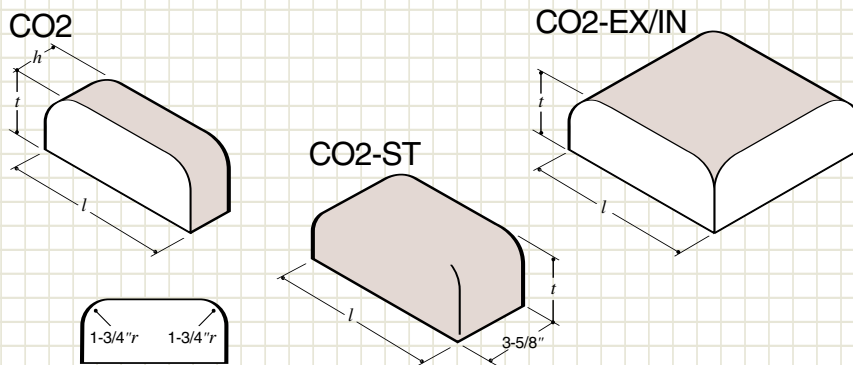

CO2	<i>t</i>	<i>h</i>	<i>l</i>
STANDARD	3-5/8"	2-1/4"	8"
STANDARD MOD	3-5/8"	2-1/4"	7-5/8"
ENGINEER STD	3-5/8"	2-3/4"	8"
ENGINEER MOD	3-5/8"	2-3/4"	7-5/8"
ECONOMO	3-5/8"	3-5/8"	7-5/8"
UTILITY	3-5/8"	3-5/8"	11-5/8"
HMOS	4"	2-3/4"	8-1/2"

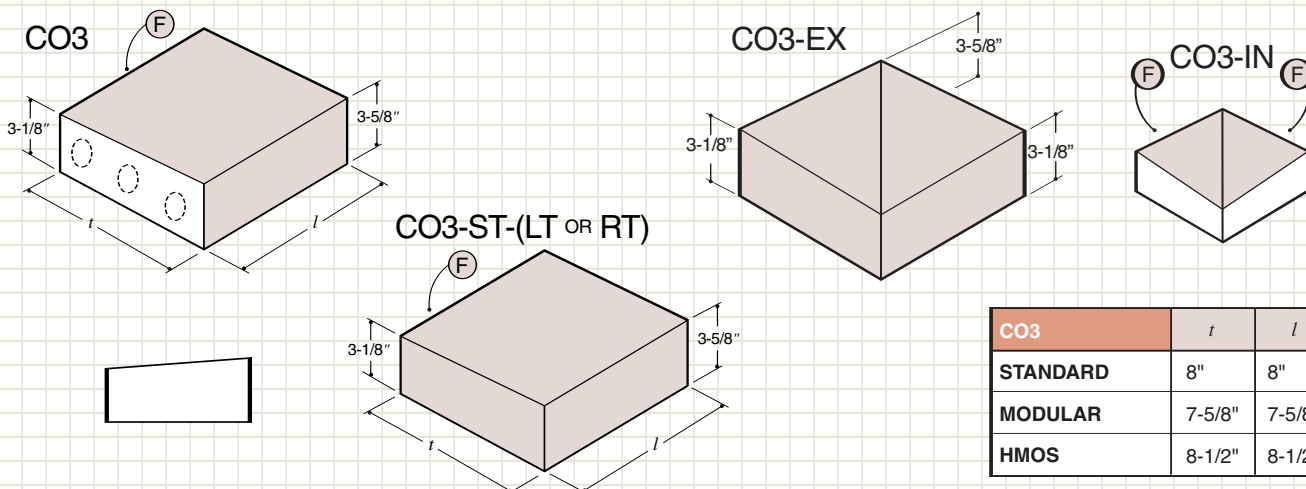

CO3	<i>t</i>	<i>l</i>
STANDARD	8"	8"
MODULAR	7-5/8"	7-5/8"
HMOS	8-1/2"	8-1/2"

Copings and Treads

CO4
 Dimensions: 10" length, 1-1/2" height, 2" depth, thickness *t*.

CO4-EX/IN
 Dimensions: 10" length, 3-1/2" height, thickness *t*.

CO4-ST
 Dimensions: 10" length, 6" width, 3-1/2" height, thickness *t*.

CO5
 Dimensions: 12" length, 4" height, 5/16" depth, thickness *t*.

CO5-ST
 Dimensions: 12" length, 6" width, 4" height, thickness *t*.

CO5-EX/IN
 Dimensions: 12" length, 4" height, thickness *t*.

CO4-EX/IN 2-PIECE OPTION (DRAWINGS REQUIRED)

CO4 or CO5	<i>t</i>
STANDARD	3-5/8"
STANDARD MOD	3-5/8"
ENGINEER STD	3-5/8"
ENGINEER MOD	3-5/8"
ECONOMO	3-5/8"
UTILITY	3-5/8"
HMOS	4"

T1-3^{5/8}"
 Dimensions: 7-5/8" length, 3-5/8" width, 2-1/4" height, 7-5/8" depth.

T1-7^{5/8}"
 Dimensions: 8-3/4" length, 1-1/8"r radius.

T1-CR-(LT OR RT)-3^{5/8}"
 Dimensions: 7-5/8" length, 3-5/8" width.

T1-CR-7^{5/8}"
 Dimensions: 7-5/8" length, 7-5/8" width.

T2-3^{5/8}"
 Dimensions: 7-5/8" length, 3-5/8" width, 2-1/4" height, 7-1/16" depth.

T2-7^{5/8}"
 Dimensions: 8" length, 15/16"r radius, 3/8" depth.

T2-CR-(LT OR RT)-3^{5/8}"
 Dimensions: 3-5/8" length, 7-1/16" width.

T2-CR-7^{5/8}"
 Dimensions: 7-1/16" length, 7-1/16" width.

T3-4"
T3-8^{1/2}" **HMOS ONLY**
 Dimensions: 8-1/2" length, 4" width, 2-1/4" height, 7" depth.

T3-CR-(LT OR RT)-4"
 Dimensions: 4" length, 7" width, 3/8" depth, 7/8"r radius, 5/8"r radius.

T3-CR-8^{1/2}"
 Dimensions: 7" length, 7" width.

Corner Brick

The octagon and hingebrick are designed to provide alternative corner treatments that do not require field cutting. The octagon brick shapes form 135° interior or exterior angles while maintaining coursing and visual continuity.

The unique design of the hingebrick offers even greater design flexibility. It allows an unlimited range of angles at corners and can be adapted for use in other brickwork details.

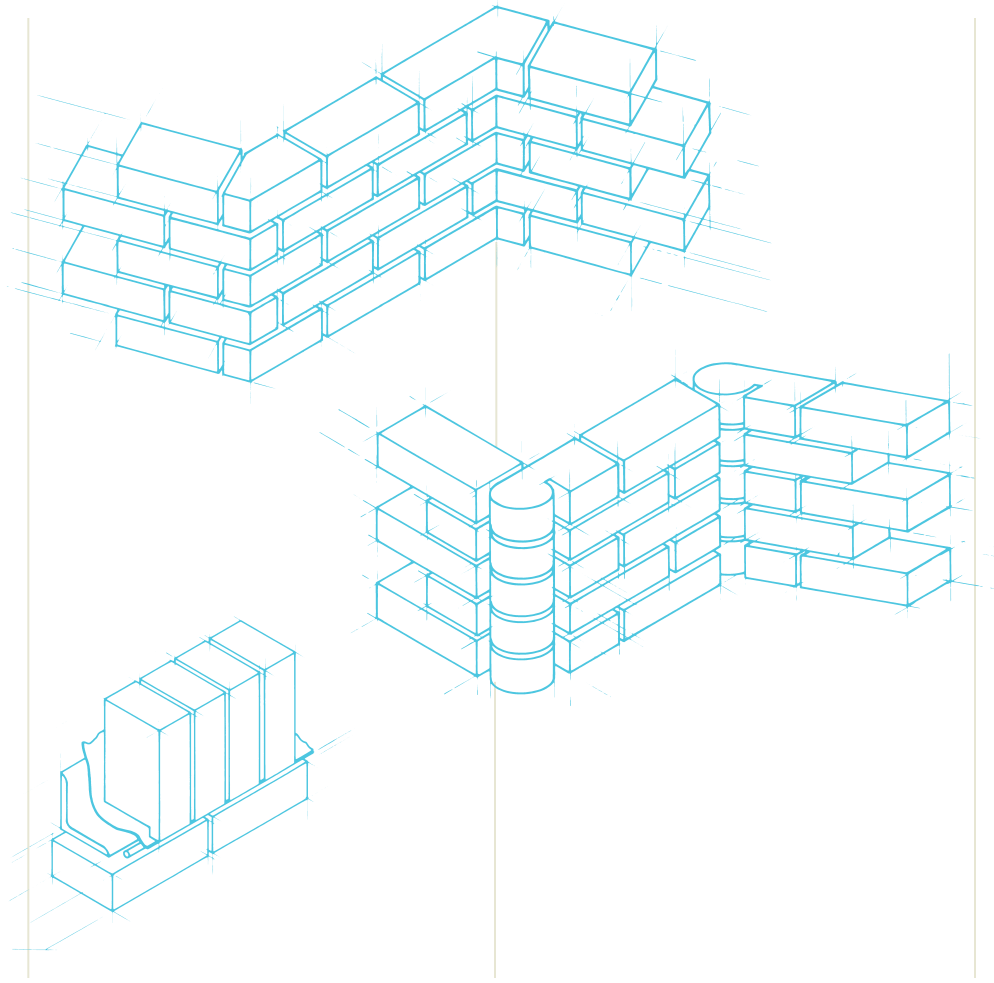

Lipped Brick

When used with a structurally fixed shelf angle, lipped brick provide inconspicuous, vertical expansion joints for brick masonry structures. They can also be used with loose shelf angles to form lintels above window and door openings.

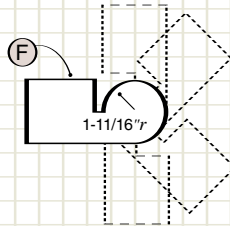
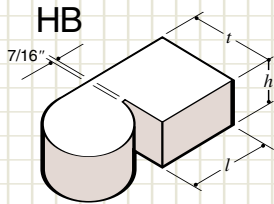

HINGEBRICK	<i>t</i>	<i>h</i>	<i>l</i>
STANDARD	3-5/8"	2-1/4"	3-13/16"
STANDARD MOD	3-5/8"	2-1/4"	3-5/8"
ENGINEER STD	3-5/8"	2-3/4"	3-13/16"
ENGINEER MOD	3-5/8"	2-3/4"	3-5/8"
ECONOMO	3-5/8"	3-5/8"	3-5/8"
*UTILITY	3-5/8"	3-5/8"	3-5/8"
HMOS	4"	2-3/4"	4"

* 1/3 Bond

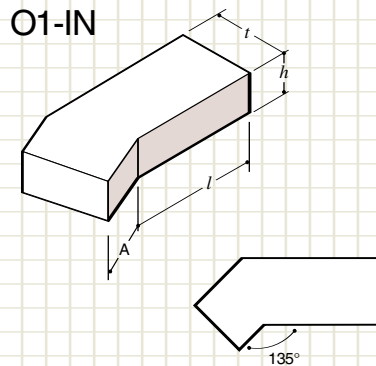
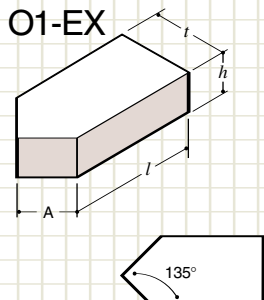

O1-EX & O1-IN	<i>t</i>	<i>h</i>	<i>l</i>	A
STANDARD	3-5/8"	2-1/4"	6-3/16"	2"
STANDARD MOD	3-5/8"	2-1/4"	6"	2"
ENGINEER STD	3-5/8"	2-3/4"	6-3/16"	2"
ENGINEER MOD	3-5/8"	2-3/4"	6"	2"
ECONOMO	3-5/8"	3-5/8"	6"	2"
*UTILITY	3-5/8"	3-5/8"	6"	2"
**UTILITY	3-5/8"	3-5/8"	8"	2"
HMOS	4"	2-3/4"	6-7/8"	2-3/8"

*1/3 Bond **1/2 Bond

Corners, Lipped, and Radials

Glen-Gery's corner, lipped, and radial brick shapes are manufactured to provide the masonry units necessary to achieve sound brickwork detailing while offering greater design flexibility.

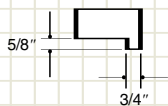
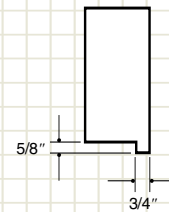
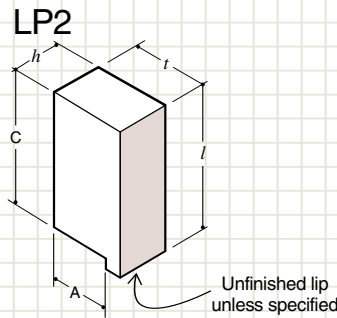
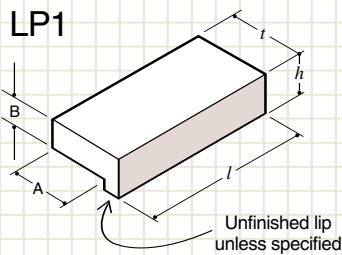

LP2-CR-(LT or RT)

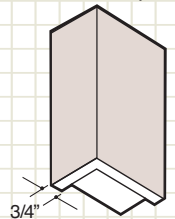

(BOTTOM VIEW)

LP1-CR-(LT or RT)

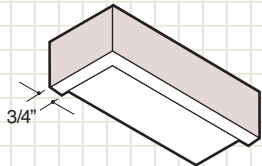

(BOTTOM VIEW)

LP1 & LP2	<i>t</i>	<i>h</i>	<i>l</i>	A	B	C
STANDARD	3-5/8"	2-1/4"	8"	2-7/8"	1-5/8"	7-3/8"
STANDARD MOD	3-5/8"	2-1/4"	7-5/8"	2-7/8"	1-5/8"	7"
ENGINEER STD	3-5/8"	2-3/4"	8"	2-7/8"	2-1/8"	7-3/8"
ENGINEER MOD	3-5/8"	2-3/4"	7-5/8"	2-7/8"	2-1/8"	7"
ECONOMO	3-5/8"	3-5/8"	7-5/8"	2-7/8"	3"	7"
UTILITY	3-5/8"	3-5/8"	11-5/8"	2-7/8"	3"	11"
HMOS	4"	2-3/4"	8-1/2"	3-1/4"	2-1/8"	7-7/8"

Radials

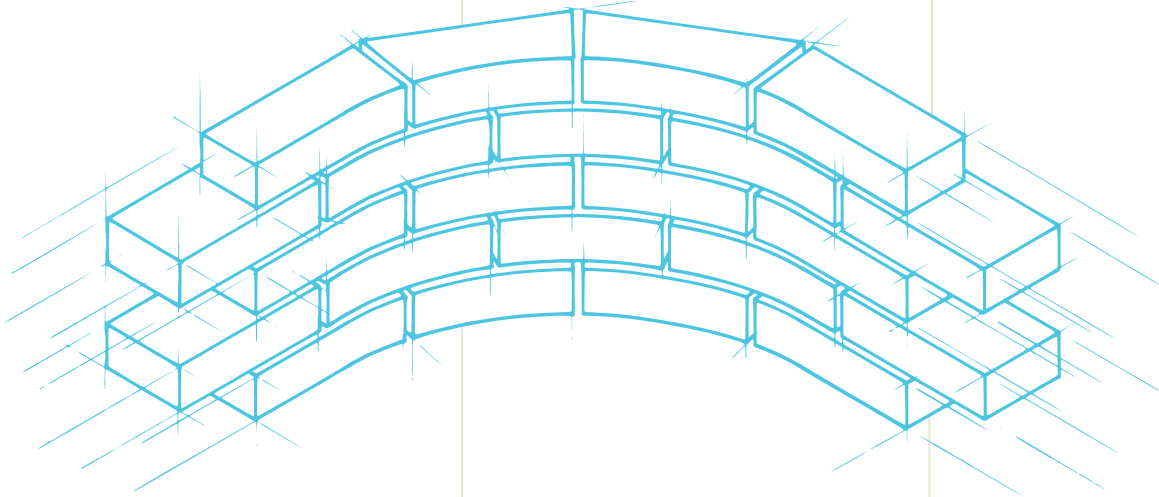

Radial Brick

Internal and external radial brick shapes, along with their companion starters, can be used to create details ranging from curtain-like walls to towering columns. These shapes are designed to form smooth, sweeping curves in brickwork without producing shadows or requiring field cuts.

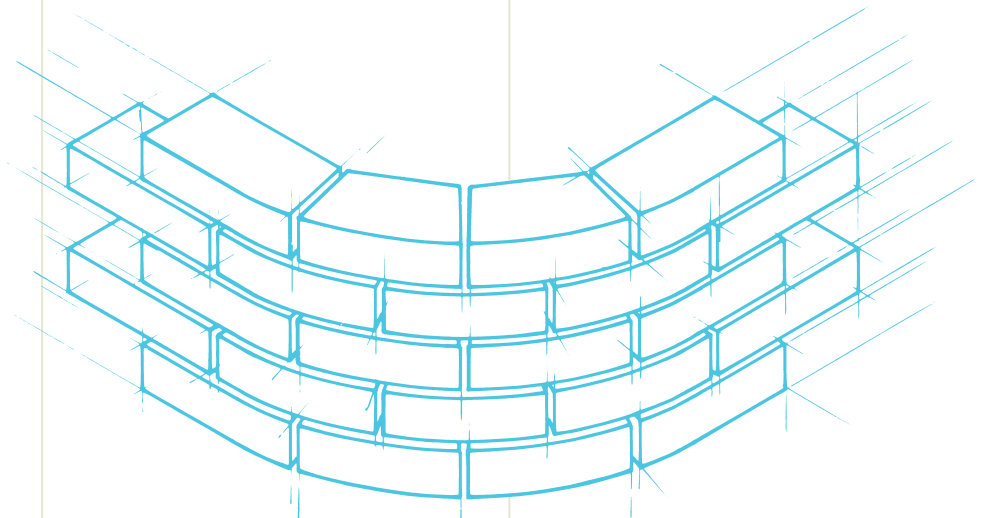

FPO-10436

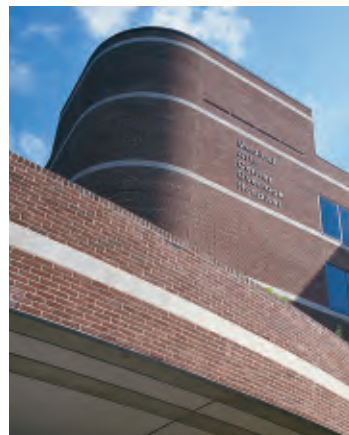

Dimensions for Glen-Gery's standardized radial brick are computed so that the arc length appears equal to the length of the accompanying stretcher units. They are also designed so that a whole number of brick fall within a 90° segment, eliminating the need to cut brick to achieve tangency at 90°, 180° or 270°.

Other radii are available as custom shapes and require architectural drawings.

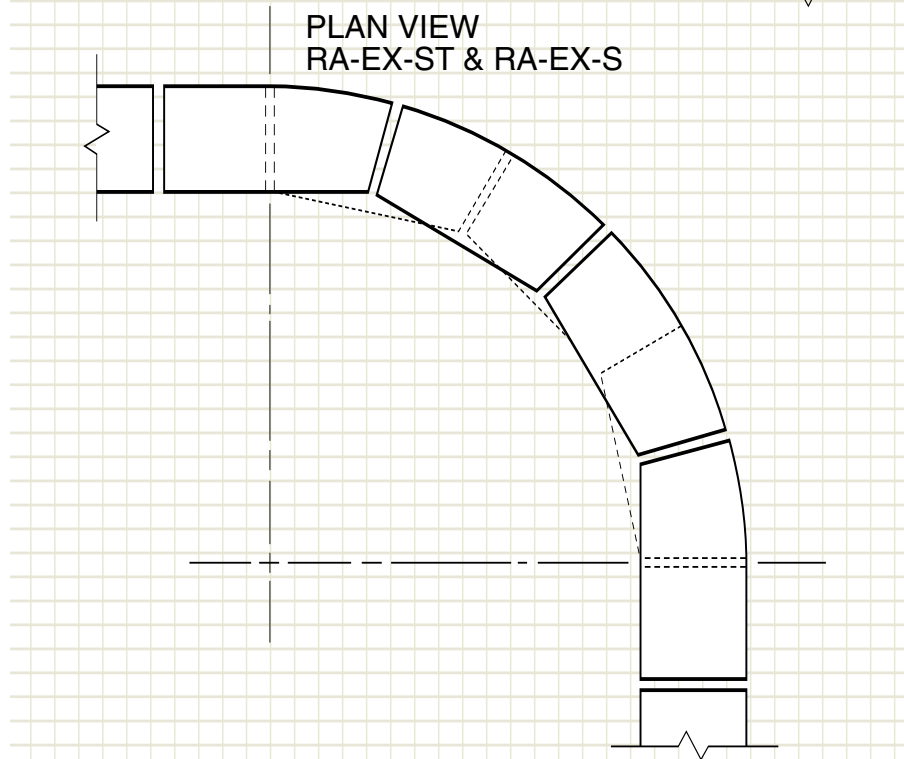
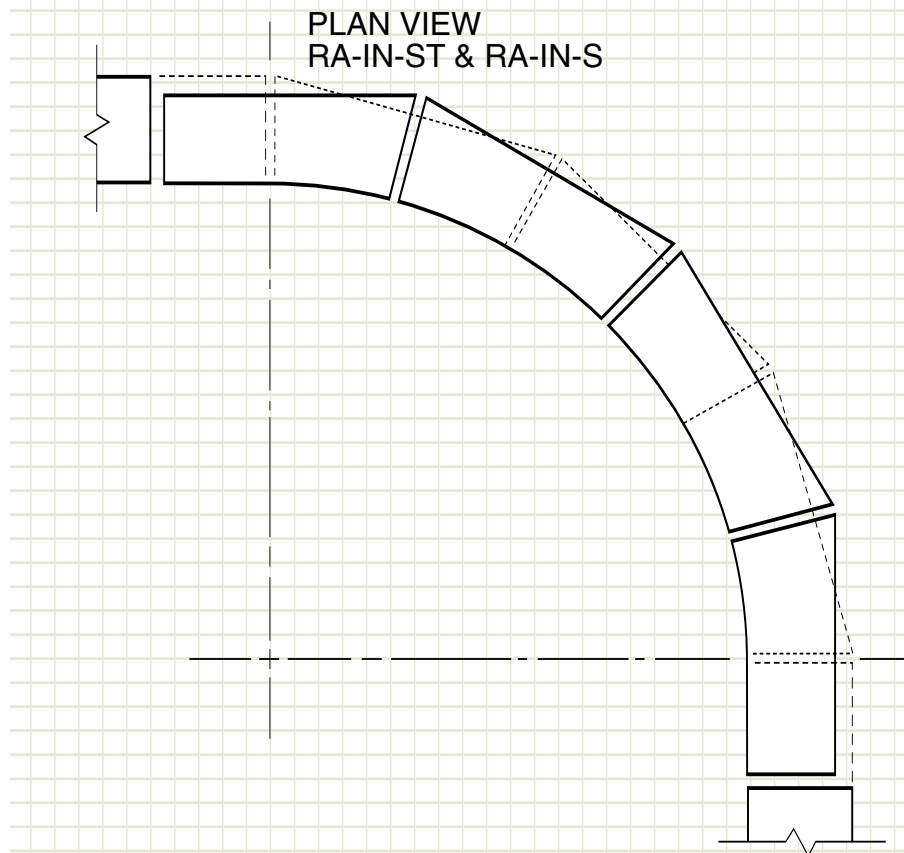

Radials

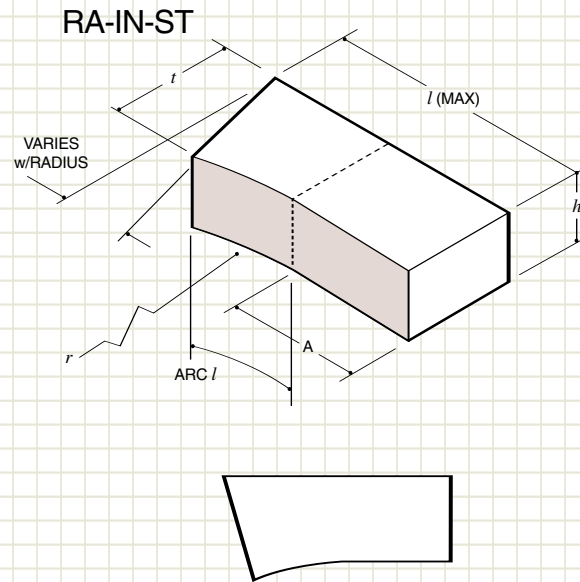
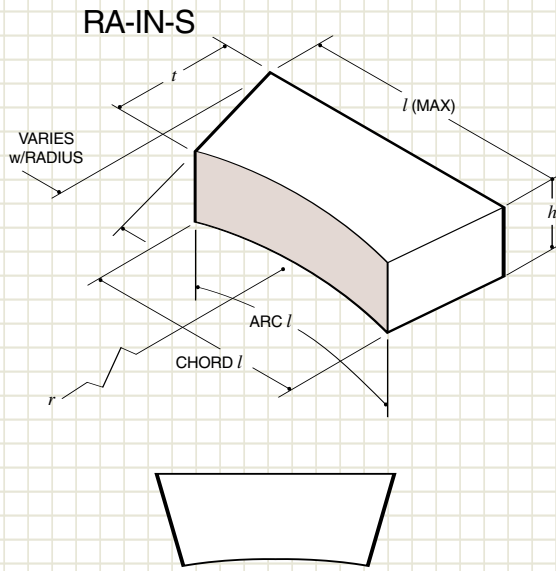

RA-IN-S	t	h	l (MAX)
*STANDARD	3-5/8"	2-1/4"	11-5/8"
*STANDARD MOD	3-5/8"	2-1/4"	11-5/8"
*ENGINEER STD	3-5/8"	2-3/4"	11-5/8"
*ENGINEER MOD	3-5/8"	2-3/4"	11-5/8"
*ECONOMO	3-5/8"	3-5/8"	11-5/8"
**UTILITY	3-5/8"	3-5/8"	11-5/8"
*HMOS	4"	2-3/4"	11-5/8"

RA-IN-ST	t	h	A	l (MAX)	
*STANDARD	3-5/8"	2-1/4"	4"	11-5/8"	
*STANDARD MOD	3-5/8"	2-1/4"	3-13/16"	11-5/8"	
*ENGINEER STD	3-5/8"	2-3/4"	4"	11-5/8"	
*ENGINEER MOD	3-5/8"	2-3/4"	3-13/16"	11-5/8"	
*ECONOMO	3-5/8"	3-5/8"	3-13/16"	11-5/8"	
**UTILITY	1/2 BOND	3-5/8"	3-5/8"	5-13/16"	11-5/8"
	1/3 BOND	3-5/8"	3-5/8"	3-13/16"	11-5/8"
	2/3 BOND	3-5/8"	3-5/8"	7-13/16"	11-5/8"
*HMOS	4"	2-3/4"	4-1/4"	11-5/8"	

*Standardized radii available in all brick sizes except utility.

RADII	ARC l	CHORD l	#/90°
16"	8"	7-15/16"	3
24"	7-3/16"	7-1/8"	5
36"	7-11/16"	7-11/16"	7
48"	8"	8"	9
60"	7-1/2"	7-1/2"	12

*Standardized radii available in all brick sizes except utility.

RADII	ARC l
16"	4"
24"	3-9/16"
36"	3-13/16"
48"	4"
60"	3-3/4"

**Standardized radii available in utility size unit.

RADII	ARC l	CHORD l	#/90°
24"	9-1/16"	9"	4
36"	9-1/16"	9"	6
48"	10-3/8"	10-3/8"	7
60"	10-1/16"	10-1/16"	9

**Standardized radii available in utility size unit.

RADII	ARC l		
	1/2B	1/3B	2/3B
24"	4-1/2"	6"	3"
36"	4-1/2"	6"	3"
48"	5-3/16"	6-7/8"	3-7/16"
60"	5"	7-1/4"	3-3/8"

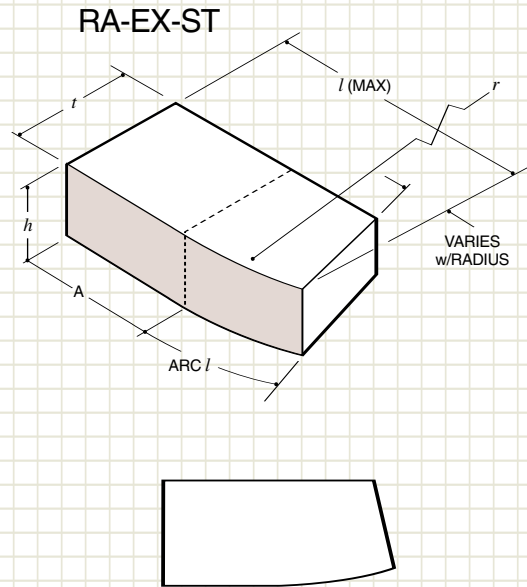
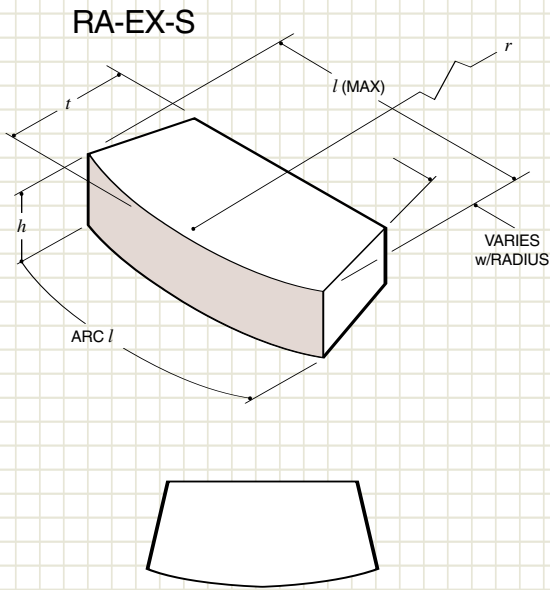

RA-EX-S	t	h	l (MAX)
*STANDARD	3-5/8"	2-1/4"	8"
*STANDARD MOD	3-5/8"	2-1/4"	7-5/8"
*ENGINEER STD	3-5/8"	2-3/4"	8"
*ENGINEER MOD	3-5/8"	2-3/4"	7-5/8"
*ECONOMO	3-5/8"	3-5/8"	7-5/8"
**UTILITY	3-5/8"	3-5/8"	11-5/8"
*HMOS	4"	2-3/4"	8-1/2"

RA-EX-ST	t	h	A	l (MAX)	
*STANDARD	3-5/8"	2-1/4"	4"	8"	
*STANDARD MOD	3-5/8"	2-1/4"	3-13/16"	7-5/8"	
*ENGINEER STD	3-5/8"	2-3/4"	4"	8"	
*ENGINEER MOD	3-5/8"	2-3/4"	3-13/16"	7-5/8"	
*ECONOMO	3-5/8"	3-5/8"	3-13/16"	7-5/8"	
**UTILITY	1/2 BOND	3-5/8"	3-5/8"	5-13/16"	11-5/8"
	1/3 BOND	3-5/8"	3-5/8"	3-13/16"	11-5/8"
	2/3 BOND	3-5/8"	3-5/8"	7-13/16"	11-5/8"
*HMOS	4"	2-3/4"	4-1/4"	8-1/2"	

*Standardized radii available in all brick sizes except utility.

RADII	ARC l	#/90°
16"	8"	3
24"	7-3/16"	5
36"	7-11/16"	7
48"	8"	9
60"	7-1/2"	12

*Standardized radii available in all brick sizes except utility.

RADII	ARC l
16"	3-1/16"
24"	3"
36"	3-7/16"
48"	3-11/16"
60"	3-1/2"

**Standardized radii available in utility size unit.

RADII	ARC l	#/90°
24"	9-1/16"	4
36"	10-5/16"	5
48"	10-3/8"	7
60"	11-3/8"	8

**Standardized radii available in utility size unit.

RADII	ARC l		
	1/2B	1/3B	2/3B
24"	4-1/2"	6"	3"
36"	5-7/16"	7-1/4"	3-5/8"
48"	5-3/16"	6-7/8"	3-7/16"
60"	5-11/16"	7-1/2"	3-3/4"

Flat Arch

Glen-Gery's flat arches achieve the look of the classical jack arch without the cost of custom-made arch pieces. The voussoirs are designed with a 70° skew-back angle and 3/8" nominal mortar joint. All the flat arch pieces, except the keystone, are the same size and shape and have parallel vertical sides. Please specify the masonry opening and the face brick unit size when ordering.

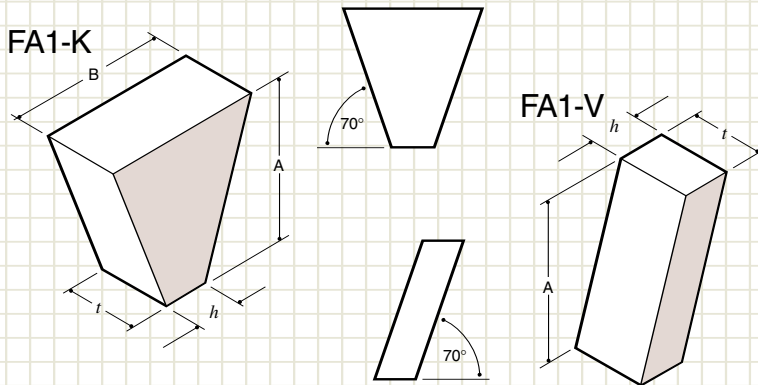
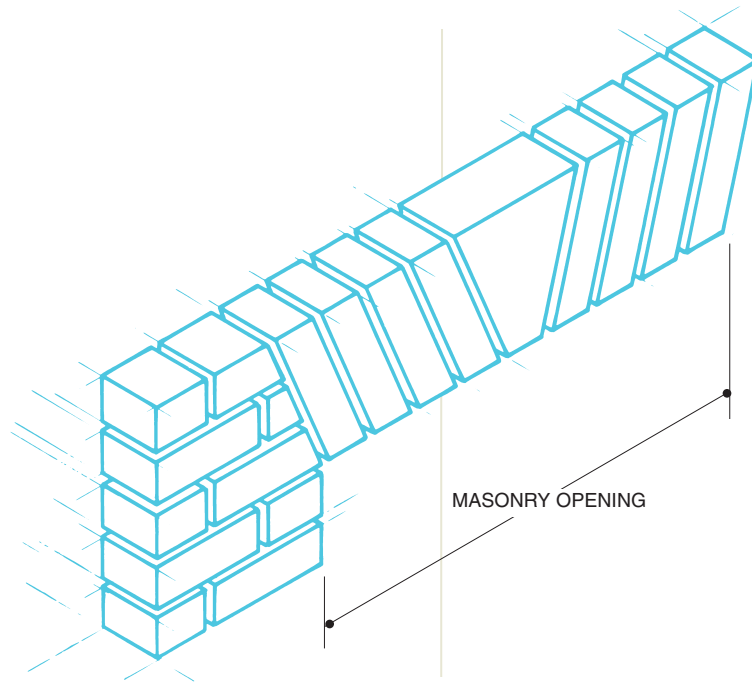

FA1-K & FA1-V	t	h	A	B
STANDARD	3-5/8"	2-1/4"	•7-5/8"	7-13/16"
STANDARD MOD	3-5/8"	2-1/4"	•7-5/8"	6"
ENGINEER STD	3-5/8"	2-3/4"	•9-1/8"	7-13/16"
ENGINEER MOD	3-5/8"	2-3/4"	•9-1/8"	6"
ECONOMO	3-5/8"	3-5/8"	◦7-5/8"	9-3/8"
UTILITY	3-5/8"	3-5/8"	◦7-5/8"	9-3/8"
HMOS	4"	2-3/4"	•9-1/8"	9-3/16"

• Equals 3 courses of companion facebrick stretchers.
◦ Equals 2 courses of companion facebrick stretchers.

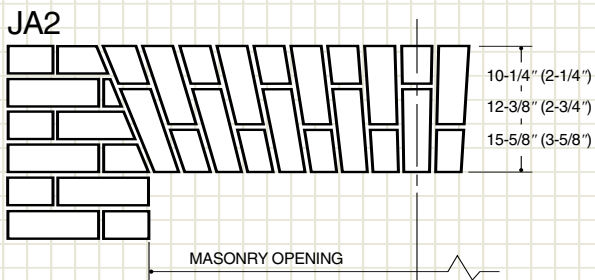
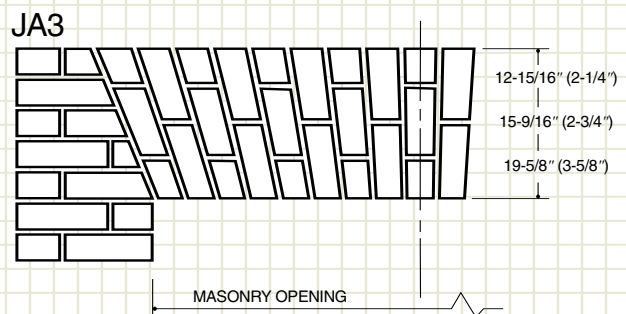
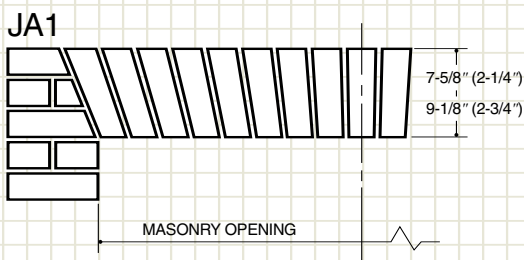

Classical Jack Arch

The typical 1, 2, and 3-brick classical jack arches, as manufactured by Glen-Gery, are calculated with a 70° skew-back angle and a 3/8" nominal mortar joint. To order a jack arch, the type of arch, masonry opening and the face brick unit size must be specified. The jack arch brick are individually boxed and tagged for location.

Arches

Brick arches invoke a sense of tradition and strength and have become a standard element in many architectural styles. For structural integrity and appeal, arches should be constructed with brick shapes to properly span the opening. Glen-Gery offers a variety of standard arches which can be used as functional or decorative elements in a building design.

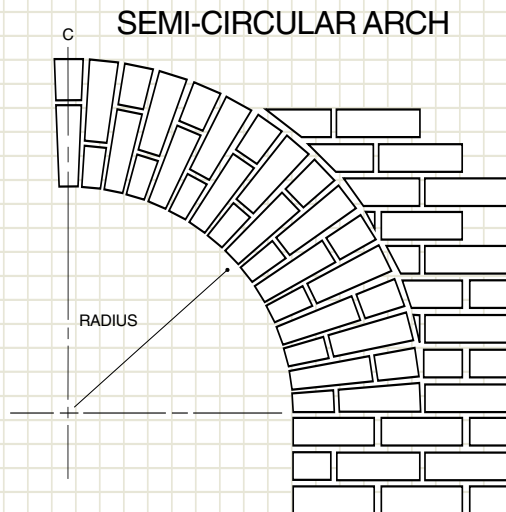

SEGMENTAL ARCH

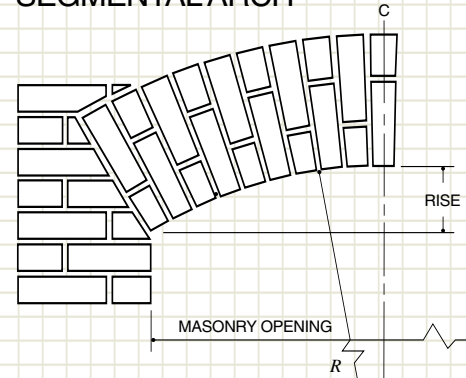

THREE-CENTERED ARCH

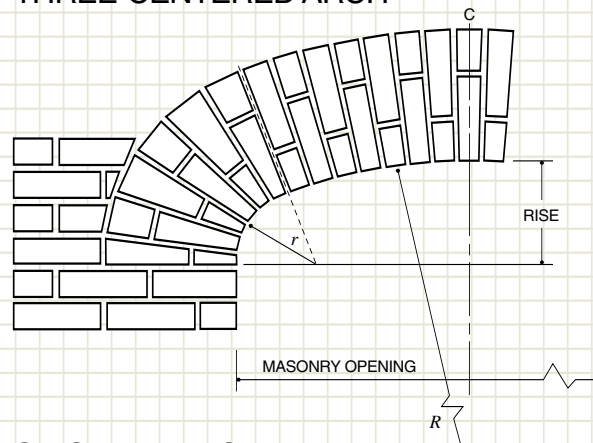

CIRCULAR ARCH

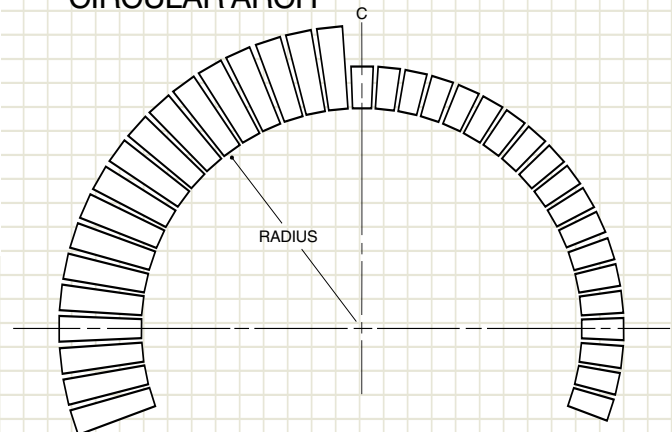

Circular, Semi-Circular, Segmental, and Three-Centered Arches

These arches are manufactured only from architects' full-size details and must include the following information:

1. Type of arch.
2. Dimension of the masonry opening.
3. Rise.
4. Thickness of the mortar joint.
5. Radii of the arch.
6. Whether it is a one or two brick arch.
7. Size of brick to be used.

Glen-Gery's team of Design Advisors will provide technical design assistance for arches or any other brickwork applications.

8-Square

Glen-Gery's 8-Square Panelbrik® and Stylo® were developed as large masonry unit alternatives for commercial construction. These large units speed construction while providing a unique pattern effect for larger structures. A system of shapes is available to enhance design flexibility. All Stylo shapes are available in wire-cut texture only.

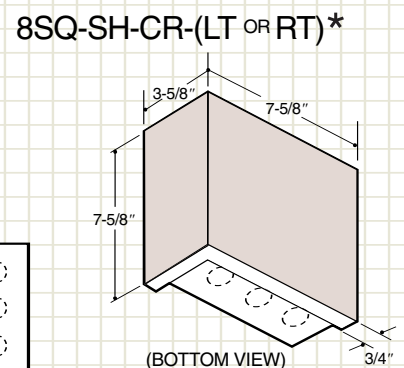
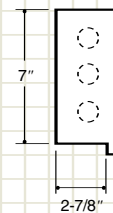
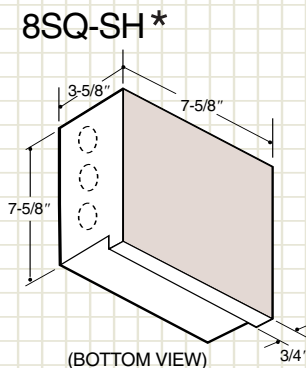
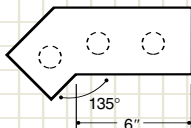
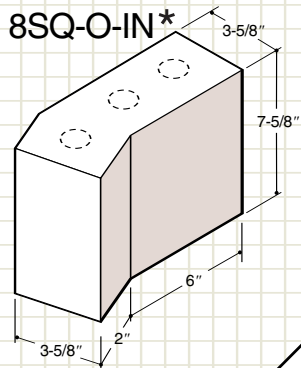
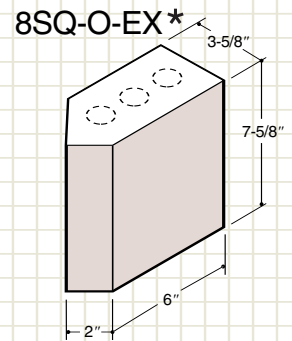
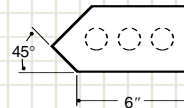
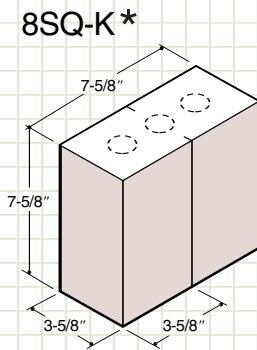
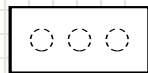
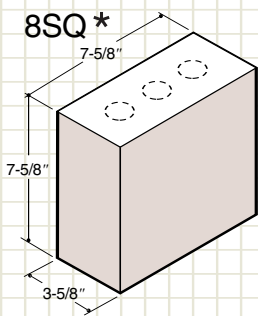

* Not available in glazed

Coated Brick



Glen-Gery's coated brick meet the highest standards of uniformity, quality, and durability. In addition to these brick shapes, Glen-Gery's Hanley plant can provide custom shapes unique to its architectural line of coated face brick.

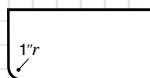
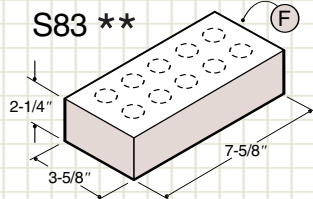
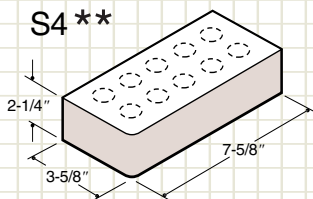
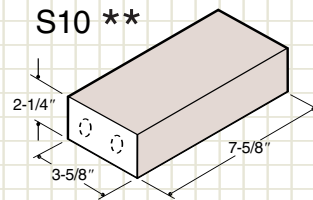
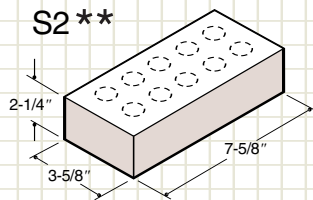

** Available in glazed & engobe

Custom Shapes

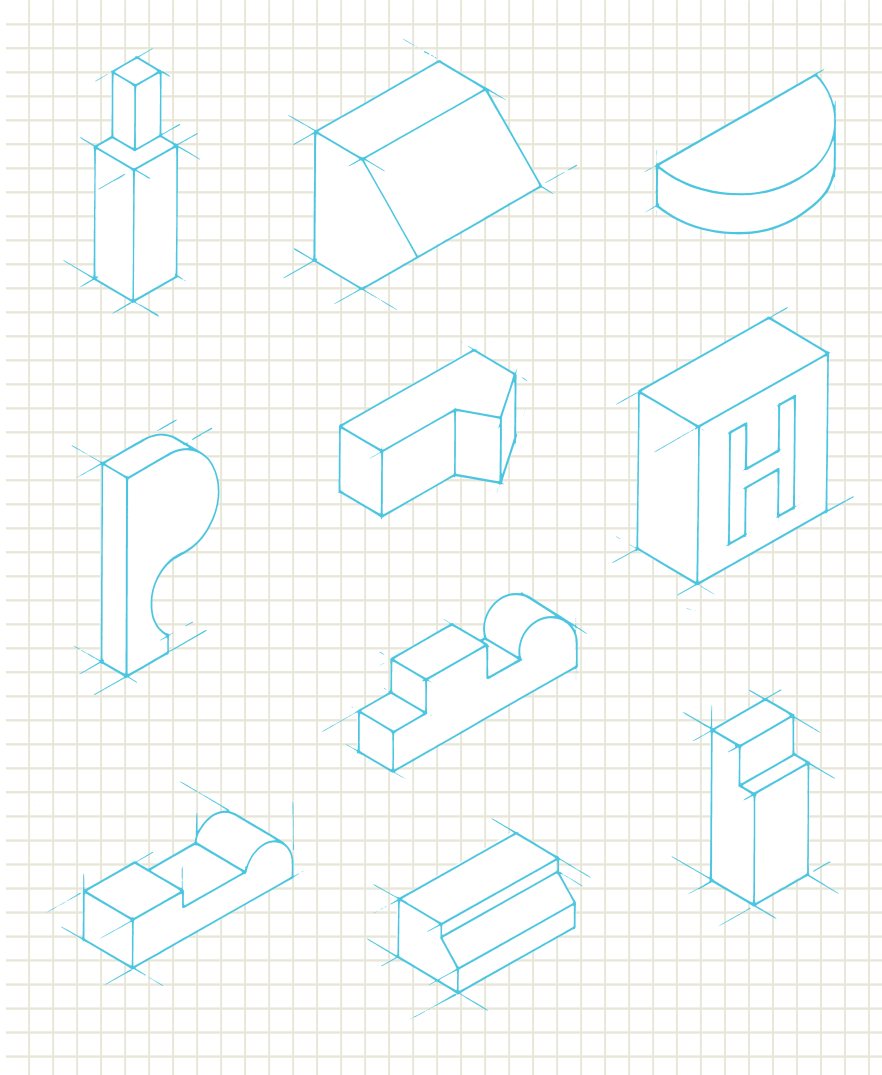

Many interesting brickwork design details can be achieved with the Glen-Gery standardized shapes illustrated in this catalog. There are projects, however, that require a custom designed brick shape to achieve a specific detail or unusual effect.

Glen-Gery welcomes the opportunity to produce unusual shapes, but it must be remembered that an intricate design demands a considerable degree of skill and expertise to make and may take longer to produce than a standardized shape. Custom shapes also require detailed, contractor-approved drawings prior to production.

Consult your Glen-Gery representative early in the project to discuss the procedure and requirements of specifying Glen-Gery custom shapes. Our technical staff and

manufacturing personnel stand ready to offer you assistance in turning your ideas into reality in the most practical and cost-effective manner.

Brick Sculptures

The ultimate brick shaping process takes place when an artist uses the material to create beautiful brick sculptures. Each sculpture can be designed to meet the requirements of the owner, the building or the environment, and can be executed in any size for interior and exterior walls or panels. From abstract to realistic, brick bas-relief adds a unique and timeless element of artistic expression to any building. Glen-Gery has experience in bringing artist and material together to create specialized sculptures. For more information, please contact your Glen-Gery representative.



Glen-Gery Corporation

SALES/BRICK CENTERS

IOWA

Glen-Gery Brick Center
101 Ashworth Road
W. Des Moines, IA 50265
TEL (515) 224-4110

KANSAS

Glen-Gery Brick Center
336 S. 42nd Street
Kansas City, KS 66106
TEL (913) 281-2800

MICHIGAN

Midwest Regional Sales Office
37720 Hills Tech Drive
Farmington Hills, MI 48331
TEL (248) 489-9338

NEW JERSEY

Northeast Regional Sales Office
75 Hamilton Road
Hillsborough, NJ 08844
TEL (908) 359-7305

PENNSYLVANIA

Glen-Gery Brick Center
2750 Commerce Drive
Turnpike Industrial Park
Middletown, PA 17057
TEL (717) 939-6061

Glen-Gery Brick Center
423 Susquehanna Trail
Watsonstown, PA 17777
TEL (570) 742-4721

Glen-Gery Brick Center
200 Hartman Road
Reading, PA 19605
TEL (610) 939-1721

Glen-Gery Brick Center
1090 E. Boundary Avenue
P.O. Box 2903
York, PA 17403
TEL (717) 854-8802

VIRGINIA

Glen-Gery Brick Centerr
9905 Godwin Drive
P.O. Box 3410
Manassas, VA 20108
TEL (703) 368-3178

MANUFACTURING FACILITIES

Bigler Plant
Bigler, PA

Caledonia Plant
Caledonia, OH

Capitol Plant
Manassas, VA

Hanley Plant
Summerville, PA

Iberia Plant
Iberia, OH

Jersey Shale Plant
Hillsborough, NJ

Marseilles Plant
Marseilles, IL

Mid-Atlantic Plant
Shoemakersville, PA

Redfield Plant
Redfield, IA

York Plant
York, PA

GLEN-GERY CORPORATION

Corporate Office
Glen-Gery Corporation
1166 Spring Street
P.O. Box 7001
Wyomissing, PA 19610-6001
(610) 374-4011
Fax: (610) 374-1622

E-Mail: gg@glengerybrick.com
<http://www.glengerybrick.com>